



- **Smallest shutter module for 230VAC up to 3 Amps. switching current**
- **Smallest power consumption, 0.7 Watts max.**
- **Fast connection to the system with appropriate shutter drive connector.**
- **Simply controlled by Casambi**

The shutter module LIGA.AIR.STO.240 is controlled by the Casambi application.

The module is directly connected to 230VAC and its outputs L1 and L2 have the capability to switch electric drive for blinds and the like with currents up to 3 Amps.

Prefabricated cables with motor plug enable a rapid connection of the shutter module to the system.

The module is capsuled in a black ABS enclosure with the dimensions of 50 x 50 x 25 mm.

The extremely compact design of the enclosure allows an easy installation in flush-mounted boxes or in a cable duct.

Dimensional drawing:

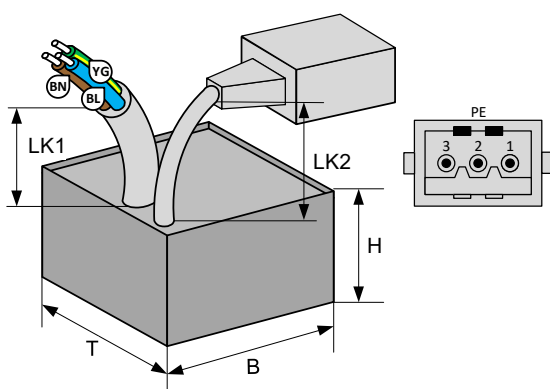

Schematics:

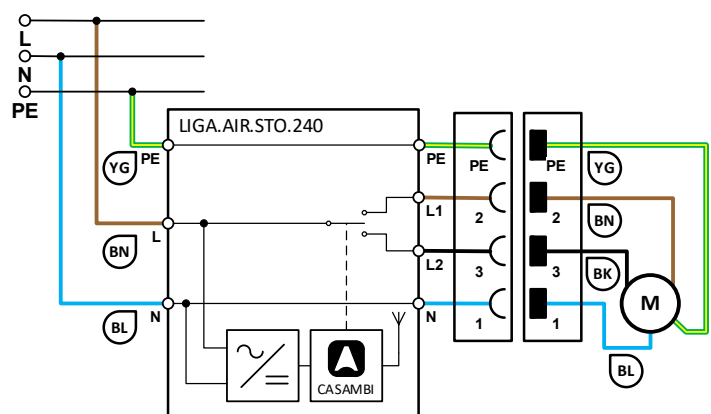

Installation only by a professional electrician according to the local regulations!



Technical specifications:

Dimension (T x B x H) / Weight	50 x 50 x 25 mm, 120g
Color	Enclosure black
Mounting	In flush-mounted boxes or cable ducts etc.
Environmental conditions, Enclosure temperature Tc	Operation: Temperature -20 ... 50°C, humidity < 85%rH Stock: Temperature -25 ... 65°C, humidity < 95%rH, Tc: 70°C
Protection type / Protection class	IP64, EN-60529 / Appliance Class II
Connections supply	Cable 3 x 1mm ² (AWG17), LK1 = LK1 mm: Brown (BN): L, phase conductor, Blue (BL): N, neutral conductor
Connections motor	Cable 4 x 1mm ² (AWG17), LK2 = LK2 mm: [Connector] Hirschmann STAK 3 Black (BK): [2] L1, T1 switched phase 1, White (WT): [3] L2, DOWN switched phase 2, Blue (BL): N, neutral conductor, Green Yellow (GY): [PE] PE protective conductor.
Max Drive time	5min, drive time can be set to any lower duration using the Casambi App with animations.
Power supply / consumption	100-240VAC, 50Hz / 0.7W
Switching outputs	3 Amp. / 230VAC (note inrush current of load)
Standards	Low Voltage Directive (LVD) 2014/35/EU, EN 60669-2-1 Electromagnetic compatibility (EMC) 2014/30/EU
CASAMBI Modul Standards	Bluetooth 4.0 Wireless Control
Switching times	Configurable with the Casambi application (App Store, Google Play)
Applications	Control of electrically driven blinds, lifts etc.
Scope of delivery	1 Shutter Module

Description

Casambi APP Operation / Action	Function
Press UP or DOWN for less than 3 seconds	Push: Drive moves in selected direction for as long as UP or DOWN remains pressed.
Pressing UP or DOWN for more than 3 seconds	Hold: The drive moves in selected direction for as long as maximum drive time, even if UP or DOWN has been released.
While the drive is moving, short press UP or DOWN	Stop: Drive stops.
Switch on MAX_UP or MAX_DOWN	Hold: The drive moves in selected direction for as long as maximum drive time. While driving, the drive can be stopped at any time with any button.
Switch off MAX_UP or MAX_DOWN	Stop: Drive stops.

Compatible devices:



iPhone 4S or later
iPad 3 or later
iPod Touch 5th gen or later.
Android 4.4 KitKat or later devices
produced after 2013 with full BT 4.0 support.

Range:

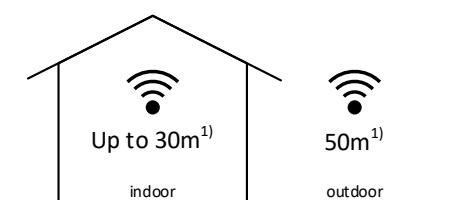

Casambi uses mesh network technology so each CBU-ASD acts also as a repeater.

Longer ranges can be achieved by using multiple Casambi units.

Range is highly dependent on the surrounding and obstacles, such as walls and building materials.





Casambi App Configuration

The configuration of two blinds «Storen Nord» and «Storen Süd» will be described as followed.

<p>View «Leuchten»</p> <p>The blind symbols of the two shutter modules «Storen-Nord» and «Storen-Süd» are accessible in the view «Leuchten».</p> <p>A long press on the desired blind symbol takes you to its operation.</p> <p>The push buttons <UP> or <DOWN> can be used for direct control of the blinds.</p> <p>The switches <MAX UP> and <MAX DOWN> are used to control the blinds via scenes and animations.</p> <p>These switches enable parallel operation of individual blinds, e.g. is required for an security «ALL UP» or a movement of the blinds for a certain period.</p> <p>The configuration of the scenes and animations is described as follows.</p>	
<p>Configuration of scenes and animations</p> <p>For the parallel operation of blinds, we first need the scenes ALL STOP, ALL UP and ALL DOWN.</p> <p>With these scenes, temporal sequences in animations can be configured. Such as ALL DOWN during 10s (ALL DOWN 10s) or ALL UP during 10s (ALL UP 10s).</p> <p>With <Bearbeiten> you switch to the view of the creation/adaptation of scenes or animations.</p>	



Configuration of Scene

A new scene can be opened with the <+> key.

First the desired name of the scene (here ALL UP) is entered and with <Szene hinzufügen> you get to the first view on the left.

By briefly pressing the greyed out blind symbols, the desired blinds are inserted into the scene.

Now the individual blinds must be configured so that they all move to the UP position.

A long press on the blind icon switches to the next view, in which the switch <MAX UP> is switched on and <MAX DOWN> is switched off.

By briefly tapping the symbol field, you can exit this view and configure the next blind.

Finally, a symbol for identification can be specified in the settings menu (orange double gear at the bottom right) of the scene.

Furthermore, the <hide> switch (<Versteckt>) determines whether the scene is displayed as an icon in the scene view and will be available to the user.

The configurations are acknowledged and ended with <Fertig>.

Following this sequence, the remaining scenes ALL AB and ALL STOP need to be created and configured.

Note:
As the different positions of the <Hidden> switch show, only the ALL STOP scene should be available to the user.

The functions ALL UP and ALL DOWN will be configured as temporary animations with the corresponding scenes in the following chapter.

Scene ALL UP

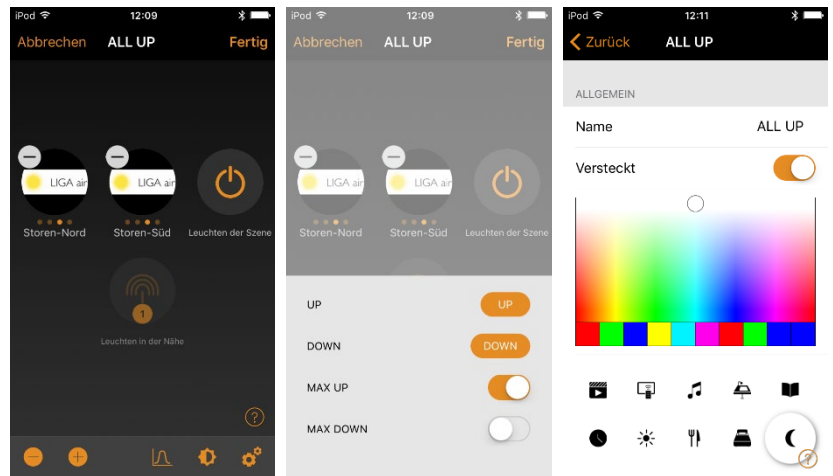

Scene ALL DOWN

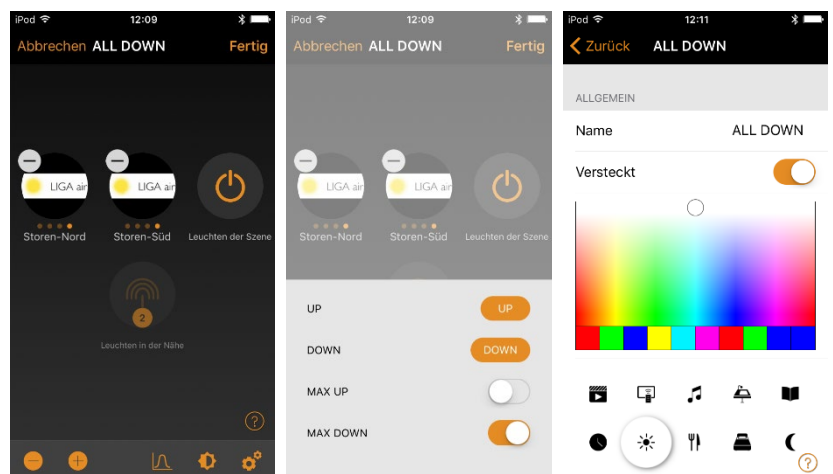

Scene ALLE STOP

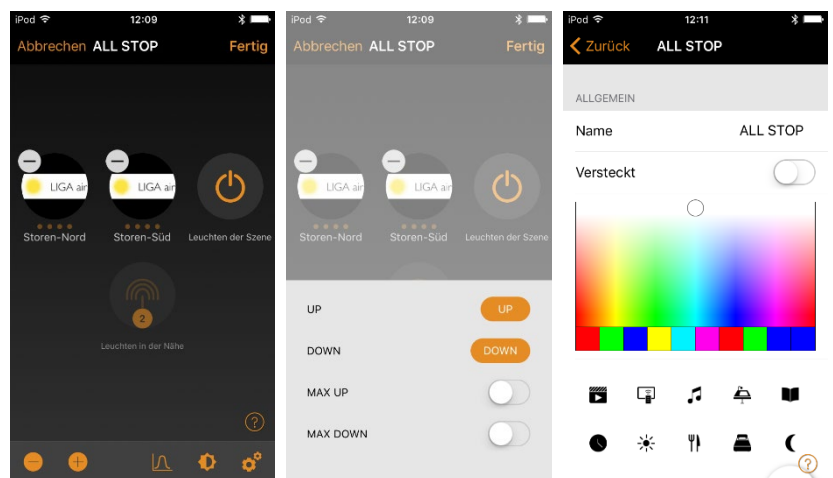



Animation erstellen

A new animation can be opened with the <+> key.

First the desired name of the animation (here ALL UP 10s) is entered and with <Animation hinzufügen> you get to the first view.

The sequence and duration of the individual scenes are now put together for the animation.

With < Szene hinzufügen > (in the second view) the desired scene can be selected and confirmed with <Fertig>. You get back to the first view.

By tapping the scene e.g. ALL STOP you get to the third view, where you can set the duration of the scene, minimum value is 1 second.

The time setting is acknowledged with <Fertig> and you return to the first view.

The first view shows the finished configuration of the animation with the sequence of scenes:
 ALL STOP for 1 second,
 ALL ON for 10 seconds and
 ALL STOP for 1 second

(With the first scene ALL STOP, the animation begins with a short idle state.)

Finally, as with a scene, the animation can be labeled with a symbol.
 It is also possible to set whether the animation should be available to the user or not.

These settings can be found in the animation configuration at the bottom (see fourth view).

After this sequence, the animation ALL AB 10s must be created and configured.

Scenes sequence:
 ALL STOP for 1 second,
 ALL DOWN for 10 seconds and
 ALL STOP for 1 second

Animation ALL UP 10s

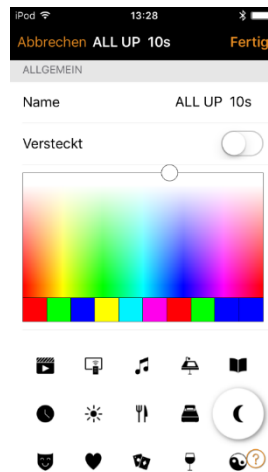
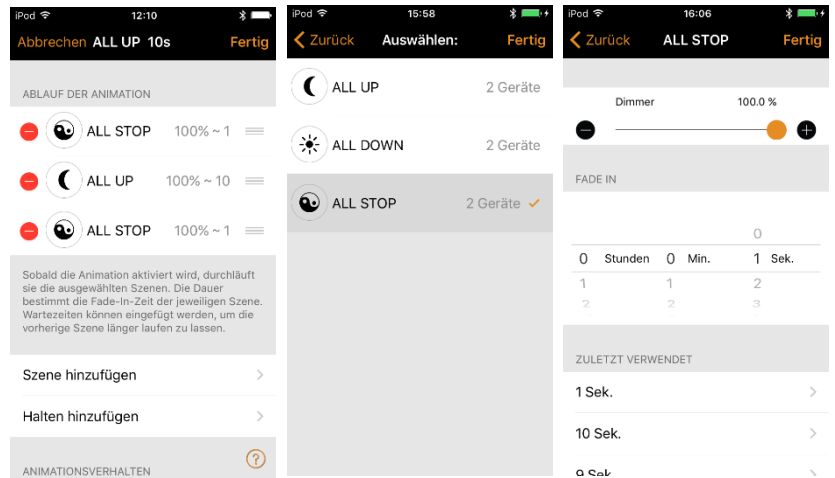

Animation ALLE DOWN 10s

